

PLAN VIEW

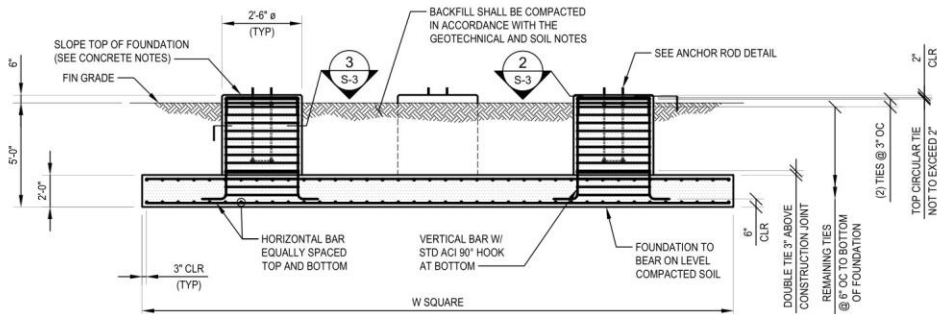

ELEVATION VIEW

| | | FOUNDATION | | | | | | | |
|-----------------------------|------------------|------------|-------------|-------------|-------------------|-----------|-----------------------------|--------------------------------|------|
| TOWER | TOWER FACE WIDTH | A | B | C | PAD WIDTH, W (FT) | OFFSET, X | HORIZONTAL BARS (QTY) #SIZE | TOTAL CONCRETE VOLUME (CU YDS) | |
| TAPERED SELF SUPPORT TOWERS | 190' | 18'-9" | 4'-4 9/16" | 8'-1 7/16" | 5'-4 15/16" | 25 | 2'-8 1/2" | (26) #7 (104 TOTAL) | 48.2 |
| | 180' | 18'-9" | 4'-4 9/16" | 8'-1 7/16" | 5'-4 15/16" | 25 | 2'-8 1/2" | (26) #7 (104 TOTAL) | 48.2 |
| | 170' | 16'-9" | 4'-2 15/16" | 7'-3 1/16" | 4'-10" | 23 | 2'-5" | (24) #7 (96 TOTAL) | 41.1 |
| | 160' | 16'-9" | 4'-2 15/16" | 7'-3 1/16" | 4'-10" | 23 | 2'-5" | (24) #7 (96 TOTAL) | 41.1 |
| | 150' | 14'-9" | 4'-1 3/8" | 6'-4 5/8" | 4'-3 1/8" | 21 | 2'-1 9/16" | (22) #7 (88 TOTAL) | 34.6 |
| | 140' | 14'-9" | 4'-1 3/8" | 6'-4 5/8" | 4'-3 1/8" | 21 | 2'-1 9/16" | (22) #7 (88 TOTAL) | 34.6 |
| | 130' | 12'-9" | 3'-11 3/4" | 5'-6 1/4" | 3'-8 3/16" | 19 | 1'-10 1/16" | (20) #7 (80 TOTAL) | 28.6 |
| | 120' | 12'-9" | 3'-11 3/4" | 5'-6 1/4" | 3'-8 3/16" | 19 | 1'-10 1/16" | (20) #7 (80 TOTAL) | 28.6 |
| | 110' | 10'-9" | 3'-10 1/8" | 4'-7 7/8" | 3'-1 1/4" | 17 | 1'-6 5/8" | (18) #7 (72 TOTAL) | 23.3 |
| | 100' | 10'-9" | 3'-10 1/8" | 4'-7 7/8" | 3'-1 1/4" | 17 | 1'-6 5/8" | (18) #7 (72 TOTAL) | 23.3 |
| | 90' | 8'-9" | 3'-8 9/16" | 3'-9 7/16" | 2'-6 5/16" | 15 | 1'-3 1/8" | (16) #7 (64 TOTAL) | 18.6 |
| | 80' | 8'-9" | 3'-8 9/16" | 3'-9 7/16" | 2'-6 5/16" | 15 | 1'-3 1/8" | (16) #7 (64 TOTAL) | 18.6 |
| | 70' | 6'-9" | 3'-6 15/16" | 2'-11 1/16" | 1'-11 3/8" | 13 | 0'-11 11/16" | (14) #7 (56 TOTAL) | 14.4 |
| | 60' | 6'-9" | 3'-6 15/16" | 2'-11 1/16" | 1'-11 3/8" | 13 | 0'-11 11/16" | (14) #7 (56 TOTAL) | 14.4 |

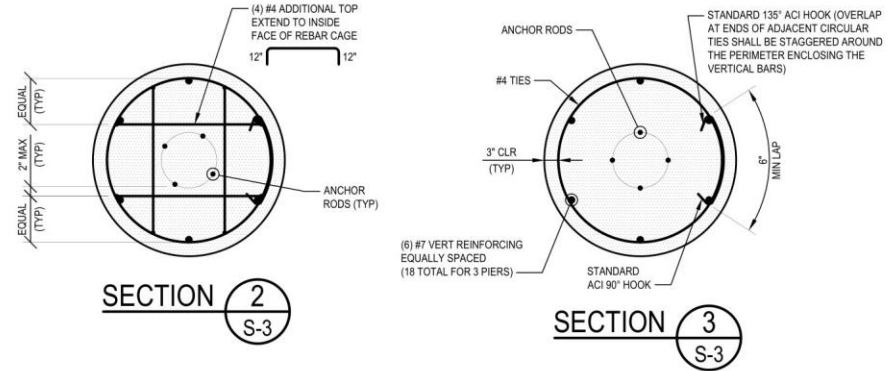

SECTION 2
S-3

SECTION 3
S-3



P. O. Box 29 Shelby, OH 44875
 info@amertower.com
 www.amertower.com
 Since 1953

Telephone
 (419) 347-1185

Fax
 (419) 347-1654

AMTO SST FOUNDATION

| | | |
|------------------|----------------|------------------|
| SIZE A | DWG NO 2852 | REV |
| DRAWN BY: TAN | | DATE 2/2/2022 |